

ANSI Z358.1 - 2009 SAFETY EQUIPMENT MINIMUM PERFORMANCE CHECKLIST

- Safety station shall be accessible within 10 seconds of hazard. (Sec. 4.5.2, 5.4.2, 6.4.2, 7.4.2)
- Safety station shall be located on the same level as the hazard and the path of travel shall be free of obstructions. (Sec. 4.5.2, 5.4.2, 6.4.2, 7.4.2)
- All employees subject to exposure to hazardous material should be instructed in the location and proper use of emergency equipment. (Sec. 4.6.4, 5.5.4, 6.5.4, 7.5.4)
- Emergency equipment shall be activated weekly. (Sec. 4.6.2, 5.5.2, 6.5.2, 7.5.2) All shower units shall be inspected annually to assure conformance with ANSI Z358.1. (Sec. 4.6.5, 5.5.5, 6.5.5, 7.5.5)
- Combination unit components shall be capable of operating simultaneously and shall be positioned so that components may be used simultaneously by the same user. (Sec. 7.3, 7.4.4)
- Drench hose must deliver a controlled flow of flushing fluid at a velocity low enough to be non-injurious. (Sec. 8.2.1)
A drench hose can only be considered an eyewash – eye/face wash if it meets performance requirements in Sec. 5 and/or 6.
- Deliver tepid flushing fluid.* (Sec. 4.5.6, 5.4.6, 6.4.6, 7.4.5)

*Suggested temperature range – above 60°F (16°C) and below 100°F (38°C).

- Showerhead must be 82 to 96 inches (208.3 cm - 243.8 cm) above surface floor of user. (Sec. 4.1.3, 7.1)
- Shower must deliver minimum of 20 gallons (75.7 L) per minute and provide a column of water 20 inches (50.8 cm) wide at 60 inches (152.4 cm) above the surface floor of user. (Sec. 4.1.2, 4.1.4, 7.1)
- Emergency equipment location shall be well lit and identified with a highly visible sign. (Sec. 4.5.3, 5.4.3, 6.4.3, 7.4.3)
- Valve shall be designed so that the flushing flow remains on without the use of the operator's hands. The valve shall be simple to operate and go from "off" to "on" in one second or less and actuator can not be more than 69 inches (173.3 cm) from surface floor of user. (Sec. 4.2, 7.1)
- Must provide a means of controlled flow to both eyes simultaneously at a velocity low enough to be non-injurious. (Sec. 5.1.1, 6.1.1, 7.1)
- Eye/face wash equipment must deliver minimum of 3 gallons (11.4 L) per minute of water for 15 minutes. (Sec. 6.1.6, 7.1) Eyewash only must deliver minimum of .4 gallon (1.5 L) per minute for 15 minutes. (Sec 5.1.6, 7.1)
- The flushing fluid of an eyewash – eye/face wash shall cover the areas between the interior and exterior lines of a gauge at some point less than 8 inches (20.3 cm) above the eyewash nozzle. (Sec. 5.1.8, 6.1.8, 7.1)
- Outlets shall be protected from airborne contaminants. (Sec. 5.1.3, 6.1.3, 7.1)
- Flushing fluid nozzles should be 33 to 45 inches (83.8 cm – 114.3 cm) from floor and minimum of 6 inches (15.3 cm) from wall. (Sec. 5.4.4, 6.4.4, 7.1)
- Valve shall be designed so that the flushing flow remains on without the use of the operator's hands. The valve shall be simple to operate and go from "off" to "on" in one second or less. (Sec. 5.2, 6.2, 7.2)

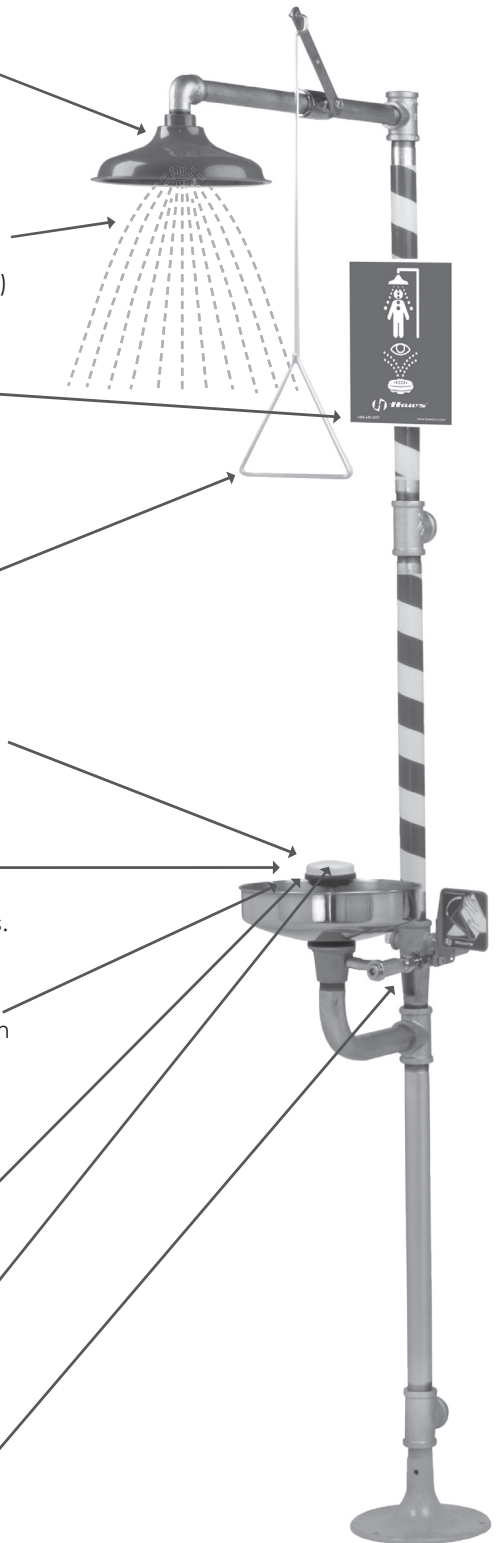

888-640-4297 :: www.hawscorp.com