



PROTECTA
INTERNATIONAL

- FULL-BODY HARNESSES
- POSITIONING DEVICES
- SHOCK-ABSORBING LANYARDS
- CONNECTING DEVICES
- GUIDED TYPE FALL ARREST
- SELF-RETRACTING LIFELINES
- CONFINED SPACE SYSTEMS
- SKYSEAT WORKING CHAIR
- EMERGENCY ESCAPE DEVICES
- ANCHORAGE DEVICES
- HEAVY LOAD FALL ARRESTORS
- HORIZONTAL LIFELINES

8748 CLAY ROAD, BUILDING 308
HOUSTON, TEXAS 77080
PHONE: (713) 460-2442
FAX: (713) 460-1990
TOLL-FREE: (800) 856-2442
www.protecta.com pro-info@protecta.com

AK200 Series

Confined Space Winch



The AK200 Series Winch for Confined Spaces is designed to facilitate safe entry and retrieval from spaces which are not designed for continuous human occupancy. The AK200 Series Winch is used in conjunction with an AK100A Tripod or AK110A Davit Arm, the AK010A1 Pulley (tripod only), a full body harness, and, in most cases, an AD Series Self-Retracting Life-line (or other fall-arrest device) to provide complete protection for confined-space entrants. The winch is man-rated by the OEM, and meets

or exceeds UL requirements (load capacity only). It is available in a variety of lengths and utilizes galvanized or stainless steel 3/16" cable or 3/16" Pro-Teq™ 12-strand fiber rope. It features a detachable handle, oil impregnated bearings, a safety lock, and a corrosion-resistant finish. Winching speed is 20fpm at a 4:1 ratio. The winch is man-rated at 310 lbs. It includes four disc brakes and is manufactured domestically. The AK200 Series Winch is simple to operate in that to reverse direction, one need only turn the handle in the opposite direction. No manipulation of components is required.

FEATURES:

- Man-rated at 310 lbs.
- Available in 30', 50', 60', 75', & 110' lengths
- Attaches to tripod with 2 locking safety pins
- Utilizes galvanized or stainless steel cable or Pro-Teq™ 12-strand rope
- Detachable adjustable square handle
- One-man setup
- Winch is installable on any leg of tripod
- Oil impregnated bearings
- Manual safety lock incorporated
- Corrosion-resistant finish
- 4:1 ratio @ 20 fpm
- Four disc brakes
- 16 lb. weight (excluding cable)
- Meets OSHA 1910/1926 and ANSI Z359.1-1992 standards for confined-space entry devices

PART NUMBER : AK200 Series

DESCRIPTION : Confined Space Winch

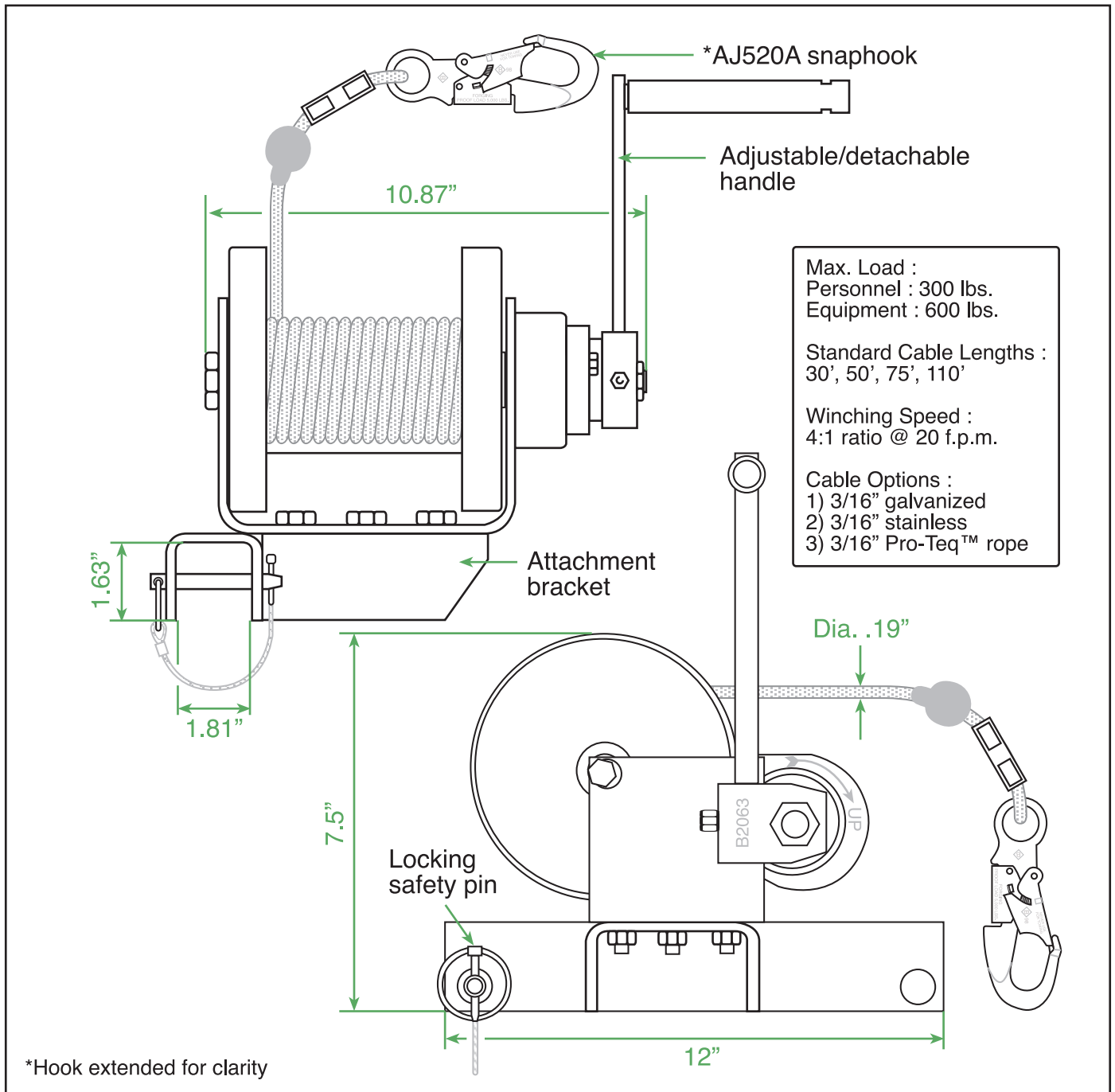

MAXIMUM LOAD : 300 lbs. (personnel, 600 lbs. (equipment))

WEIGHT : 16 lbs. (excluding cable)

CONSTRUCTION : Corrosion resistant steel. Cable available in galvanized or stainless steel or Pro-tech 12-strand rope

COMPLIANCE : OSHA 1910, ANSI Z359.1-1992

OTHER : No tools required for installation. Custom cable lengths available.