

Barrel Mount Sleeve

Model: DH-5 (Mild Steel)



Description

Zinc plated mild steel construction. 3.5" throat opening with 8 independent clamping screws allows temporary installations over edges of shoring cans, walls and other structures, comes with PVC liner.

Materials

General Construction:	Welded Steel
Weld Certification:	AWS
Structure Material:	A-36 Steel Plate
Sleeve Material:	Sch. 40 Pipe
Sleeve Bearing Material:	PVC Pipe ASTM-D-1785
Thrust Bearing Material:	High Density Polyethylene
Finish (Steel Sleeves):	Zinc Plated
Plating Specification:	ASTM Designation B633-85, Type III, SC12

Technical

Rated Capacity:	450lbs (204kg)
Working load limit @ minimum 4:1 Design Factor	
Mast Moment Proof Load	90,000 in-lbs (10,200 N.m)
Mast Rotation	360°
Weight	36lbs (16.4kg)



Application

Restrictions

1. Sleeves are for use with approved masts and accessories ONLY.
2. System design factor depends on other system components and the configurations in which they are assembled. The minimum design factor for all standard MILLER DuraHoist mast and accessories is 4:1.
3. If base material does not meet minimum requirements, reinforcement MUST be added to meet minimum requirements.
4. Each installation MUST be approved to local standards by a qualified engineer.

Barrel Mount Sleeve

Model: DH-5 (Mild Steel)

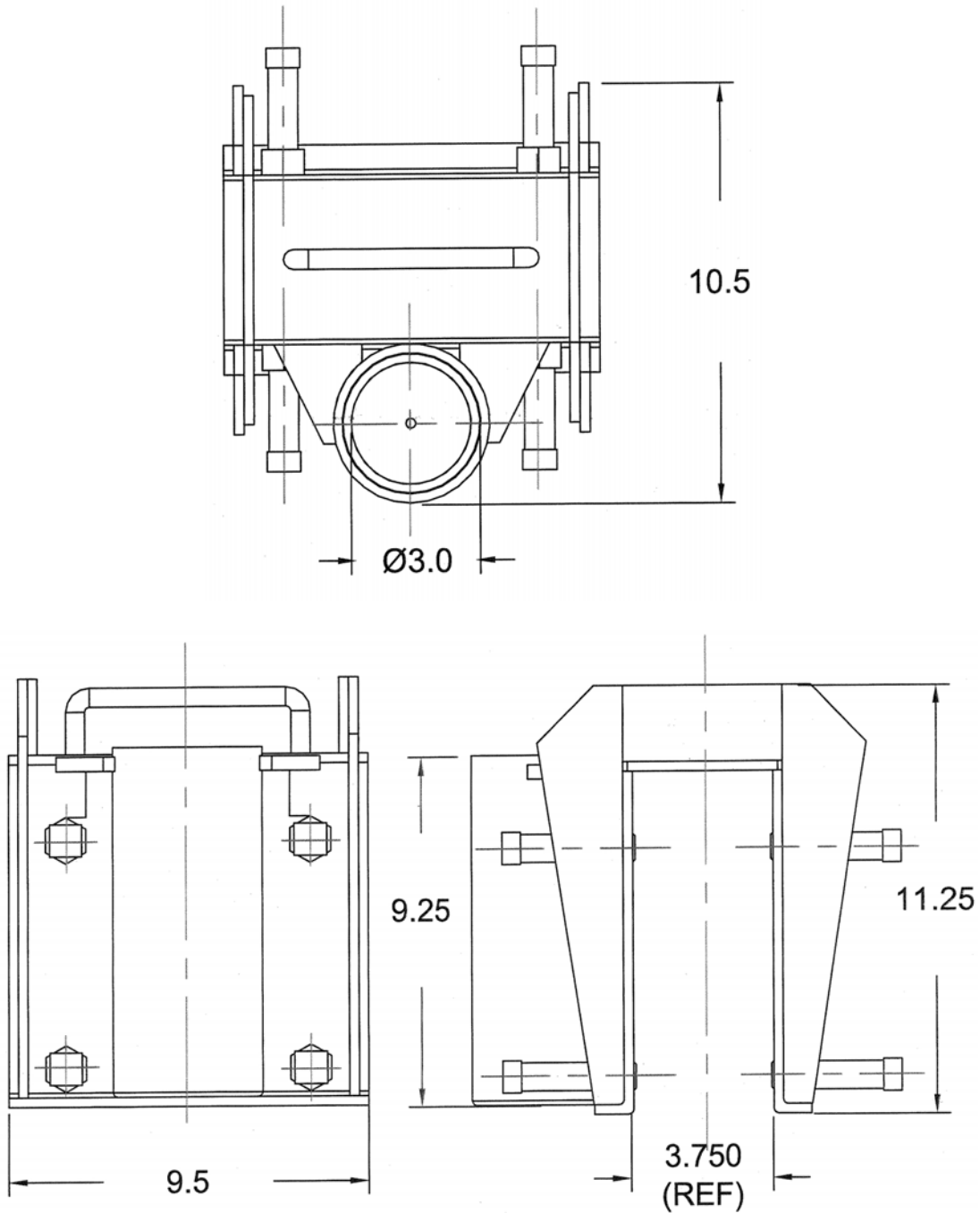

Toll Free 800-873-5242 • Phone 814.432.2118 • Fax 814.437.2973 • www.millerfallprotection.com

WARNING! THIS DOCUMENT PROVIDES AN OVERVIEW OF FALL PROTECTION PRODUCTS AVAILABLE FROM MILLER FALL PROTECTION AND CARE HAS BEEN TAKEN TO ASSURE THE ACCURACY OF THE DATA. IT DOES NOT PROVIDE IMPORTANT PRODUCT WARNINGS AND INSTRUCTIONS. MILLER FALL PROTECTION RECOMMENDS ALL USERS OF FALL PROTECTION EQUIPMENT UNDERGO THOROUGH TRAINING, AND THAT ALL WARNINGS AND INSTRUCTIONS PROVIDED WITH THE PRODUCTS BE THOROUGHLY READ AND UNDERSTOOD PRIOR TO EACH USE. FAILURE TO READ AND FOLLOW ALL PRODUCT WARNINGS AND INSTRUCTIONS COULD RESULT IN SERIOUS INJURY OR DEATH.