

Flush Floor Mount Sleeve

Model: DH-20ZP and DH-20SS



Description

Zinc plated mild steel or stainless steel construction.
Mounts to horizontal concrete or steel structures.
Includes PVC sleeve liner.

Materials

FOR DH-20ZP:

General Construction: Welded Mild Steel

Weld Certification: AWS

Base Material: A-36 Steel Plate

Material Structure: Sch.40 Pipe

Sleeve Bearing

Material: PVC Pipe
ASTM-D-1785

Thrust Bearing

Material: High Density

Polyethylene

Finish (Steel Sleeves): <125 uin machined or
Cold Rolled

Plating Specification: ASTM Designation
B633, Type II, SC2

FOR DH-20SS:

General Construction: Welded Stainless Steel

Weld Certification: AWS

Structure Material: 304 Stainless Steel Plate

Sleeve Material: Sch. 40 Pipe
ASTM-D-1785

Sleeve Bearing

Material: PVC Pipe
ASTM-D-1785

Thrust Bearing

Material: High Density

Polyethylene

Finish

(Stainless Sleeves): Sand Blasted



Technical

Rated Capacity: 450lbs (204kg) working
load limit @ minimum 4:1
Design Factor

Mast Moment

Proof Load 90,000 in-lbs (10,200 N.m)

Mast Rotation 360°

DH-20ZP Weight 24 lbs (10.9kg)

DH-20SS Weight 25 lbs (11.4kg)

Note: Sleeves are designed to withstand the proof load rating of all standard Miller DuraHoist masts.

Mounting Requirements (Minimum)

The structure and mounting hardware must be capable of withstanding a 90,000 in-lbs (10,170Nm) moment and a 5,000lb (22.2kN) vertical load. Installation MUST be approved to local regulations by a qualified engineer.

Application Restrictions

1. Sleeves are for use with approved masts and accessories ONLY.
2. System design factor depends on other system components and the configurations in which they are assembled. The minimum design factor for all standard MILLER DuraHoist mast and accessories is 4:1.
3. All welding is to be carried out by qualified personnel.
4. If base material does not meet minimum requirements, reinforcement MUST be added to meet minimum requirements.
5. Each installation MUST be approved to local standards by a qualified engineer.

Flush Floor Mount Sleeve

Model: DH-20ZP and DH-20SS

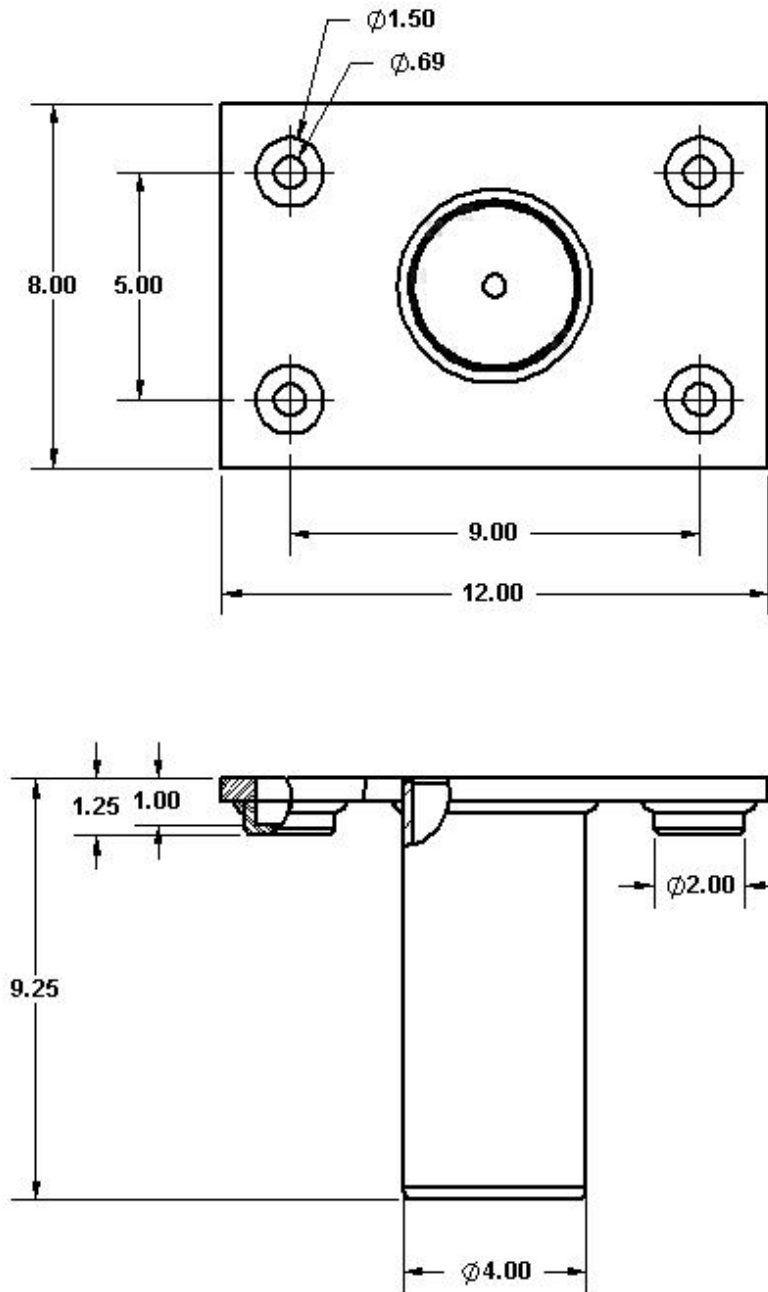

Toll Free 800-873-5242 • Phone 814.432.2118 • Fax 814.437.2973 • www.millerfallprotection.com

WARNING! THIS DOCUMENT PROVIDES AN OVERVIEW OF FALL PROTECTION PRODUCTS AVAILABLE FROM MILLER FALL PROTECTION AND CARE HAS BEEN TAKEN TO ASSURE THE ACCURACY OF THE DATA. IT DOES NOT PROVIDE IMPORTANT PRODUCT WARNINGS AND INSTRUCTIONS. MILLER FALL PROTECTION RECOMMENDS ALL USERS OF FALL PROTECTION EQUIPMENT UNDERGO THOROUGH TRAINING, AND THAT ALL WARNINGS AND INSTRUCTIONS PROVIDED WITH THE PRODUCTS BE THOROUGHLY READ AND UNDERSTOOD PRIOR TO EACH USE. FAILURE TO READ AND FOLLOW ALL PRODUCT WARNINGS AND INSTRUCTIONS COULD RESULT IN SERIOUS INJURY OR DEATH.