

Four Piece Hoist System w/ ManHandler

Model: DH-1



Description

The Four Piece Hoist System is designed for manhole and confined space entry/retrieval applications. The modular design allows use of components in various configurations and applications. Multiple winches and/or lifeline systems may be mounted as required. Tool-less design breaks the system into lightweight, manageable components for storage, transport, and setup. The DH-1 features the DH-3 Mast, DH-4 Base, and the ManHandler.

Materials

General Construction:	Welded Aluminum
Weld Certification:	AWS
Hardware:	Zinc Plated
Material Structure:	6061-T6, 5052-H32, 7075-T6 Aluminum
Block Anchor:	304 Stainless Steel
Finish:	Safety Yellow Powder Coat

Technical

Rated Capacity:	450lbs (204kg) working load limit @ minimum 4:1 Design Factor
------------------------	---

Proof Load Ratings

Anchor Points

A) Standard

Pin Position 1 & 2	5000lbs (22kN)
Pin Position 3	3600lbs (16kN)
Pin Position 4	3000lbs (13kN)

B) Optional	5000lbs (22kN)
--------------------	----------------

Winch/SRL Mount Positions

A) Rear Mount

Pin Position 1 & 2	5000lbs (22kN)
Pin Position 3	3600lbs (16kN)
Pin Position 4	3000lbs (13kN)

B) Front Mount

Pin Position 1 & 2	2500lbs (11kN)
Pin Position 3 & 4	1800lbs (8kN)

Weight

Mast Assembly	31lbs (14kg)
Base Center	30lbs (14kg)
Base Legs (x2)	30lbs (14kg)
ManHandler	39lbs (18kg)
DH-19-MILLER	3.5lbs (1.6kg)



Application Restrictions

1. All winch and block mounting parts and hardware must be supplied or approved by Miller.
2. Retractable devices or shock absorbers must be installed and used in accordance with the manufacturer's instructions.
3. Masts must be used with bases or sleeves approved for use with the applicable mast offset.
4. Where required by regulation, each installation must be approved to applicable standards by a qualified engineer.
5. All equipment must be set up and operated under the supervision of a competent person according to the manufacturer's instructions.

Four Piece Hoist System w/ ManHandler

Model: DH-1



****ALL PICTURES SHOWN WITH MINIMUM OFFSET**

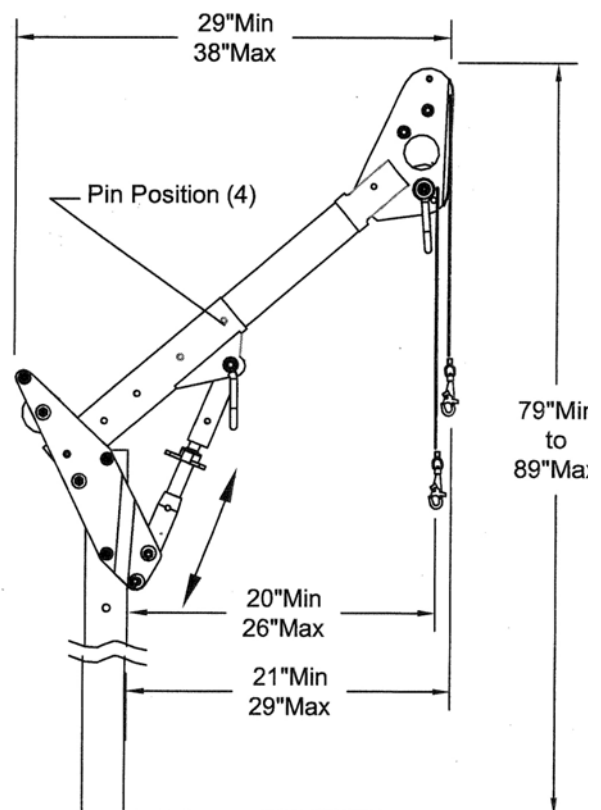
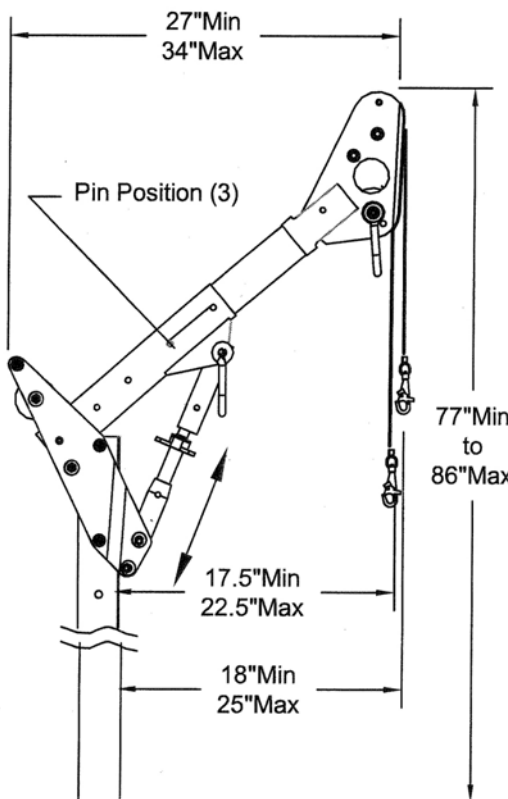
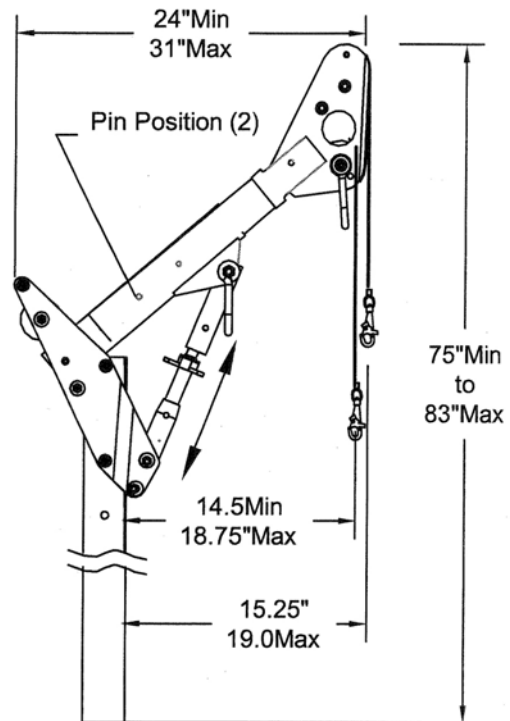
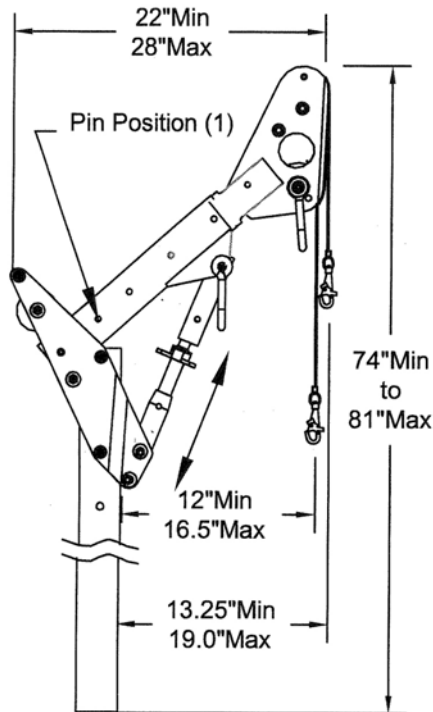

*MAXIMUM OFFSET DETERMINED WITH ADJUSTABLE GUSSET FULLY COLLAPSED (NO VISIBLE THREADS)

*MAXIMUM OFFSET DETERMINED WITH ADJUSTABLE GUSSET FULLY EXTENDED (AS SHOWN IN ALL PICTURES ABOVE)

Four Piece Hoist System w/ ManHandler

Model: DH-1

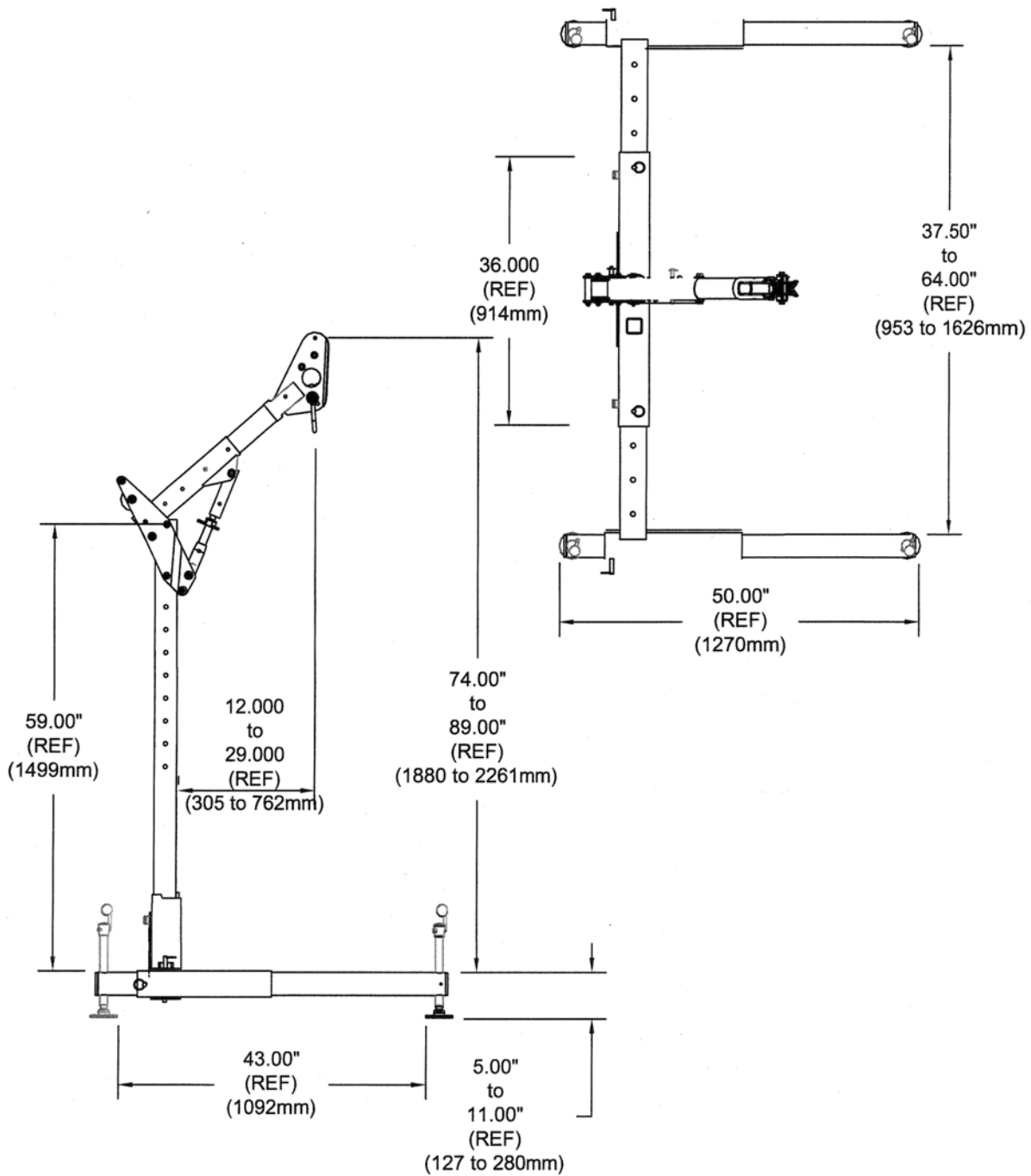

Toll Free 800-873-5242 • Phone 814.432.2118 • Fax 814.437.2973 • www.millerfallprotection.com

WARNING! THIS DOCUMENT PROVIDES AN OVERVIEW OF FALL PROTECTION PRODUCTS AVAILABLE FROM MILLER FALL PROTECTION AND CARE HAS BEEN TAKEN TO ASSURE THE ACCURACY OF THE DATA. IT DOES NOT PROVIDE IMPORTANT PRODUCT WARNINGS AND INSTRUCTIONS. MILLER FALL PROTECTION RECOMMENDS ALL USERS OF FALL PROTECTION EQUIPMENT UNDERGO THOROUGH TRAINING, AND THAT ALL WARNINGS AND INSTRUCTIONS PROVIDED WITH THE PRODUCTS BE THOROUGHLY READ AND UNDERSTOOD PRIOR TO EACH USE. FAILURE TO READ AND FOLLOW ALL PRODUCT WARNINGS AND INSTRUCTIONS COULD RESULT IN SERIOUS INJURY OR DEATH.