



PROTECTA
INTERNATIONAL

- FULL-BODY HARNESSSES
- POSITIONING DEVICES
- SHOCK-ABSORBING LANYARDS
- CONNECTING DEVICES
- GUIDED TYPE FALL ARREST
- SELF-RETRACTING LIFELINES
- CONFINED SPACE SYSTEMS
- SKYSEAT WORKING CHAIR
- EMERGENCY ESCAPE DEVICES
- ANCHORAGE DEVICES
- HEAVY LOAD FALL ARRESTORS
- HORIZONTAL LIFELINES

8748 CLAY ROAD, BUILDING 308
HOUSTON, TEXAS 77080
PHONE: (713) 460-2442
FAX: (713) 460-1990
TOLL-FREE: (800) 856-2442
www.protecta.com pro-info@protecta.com

AK010A1

Confined Space Pulley



The AK010A1 Confined Space System Pulley is designed to be used as an integral part of the AA800 Series Tripod Confined Space System. The AK010A1 is constructed of stainless steel and features a pivoting sheave for guiding the winch cable. A locking safety pin assures that the cable will stay on track, and no tools are required for installation. In addition, the unit comes complete with one AJ514A Self-Locking Carabiner for attachment to the tripod head anchor point.

FEATURES:

- Stainless steel construction
- Pivoting sheave for guiding winch cable
- Locking safety pin
- Includes one AJ514A Self-Locking Carabiner
- No tools required for installation
- Compliance with OSHA 1910 and ANSI Z359.1-1992 Standards

PART NUMBER : AK010A1

DESCRIPTION : Confined Space Pulley

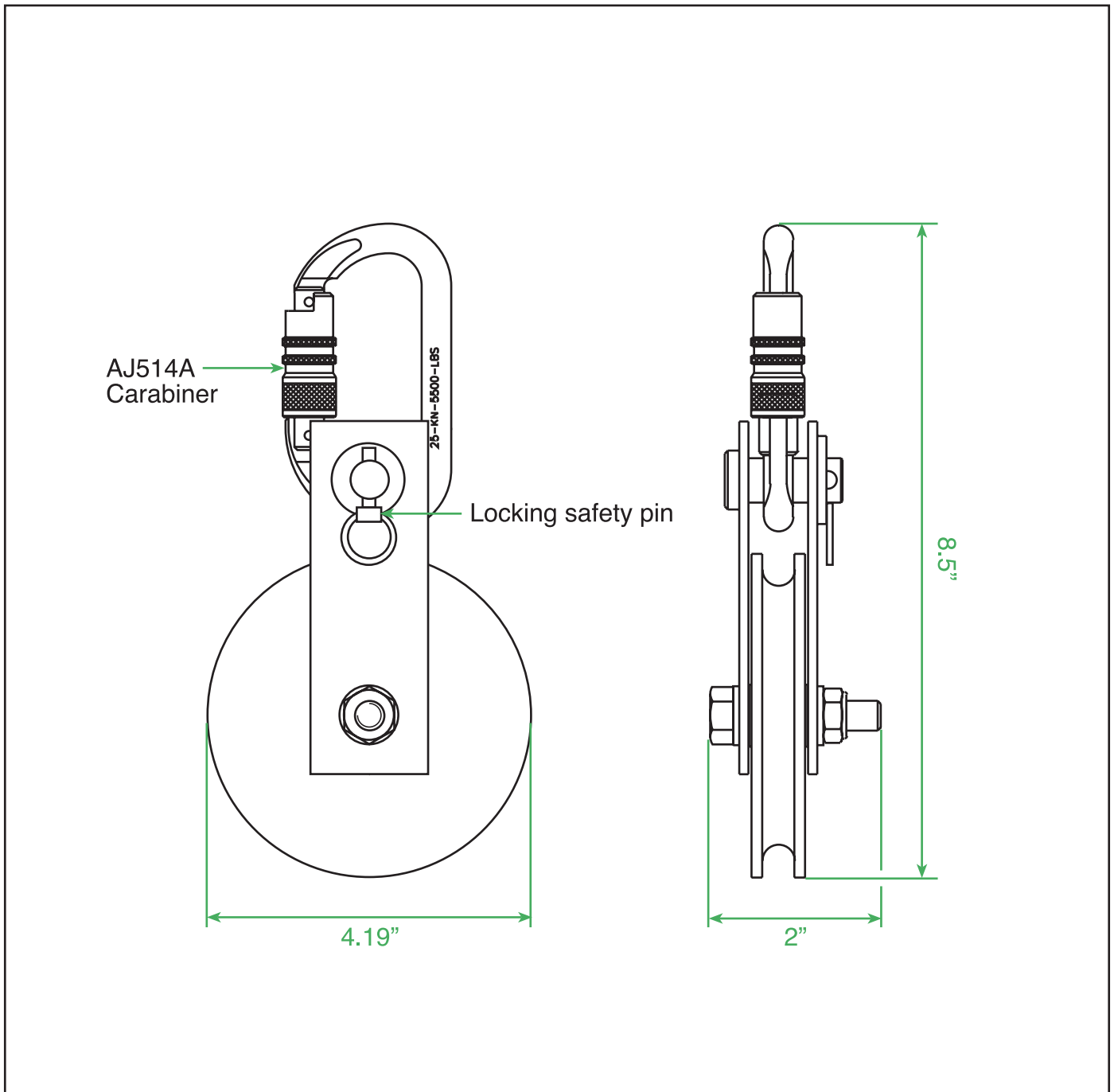

MAXIMUM LOAD : 300 lbs. (personnel), 600 lbs. (equipment)

WEIGHT : 2.04 lbs.

CONSTRUCTION : Stainles steel pulley, galvanized steel carabiner

COMPLIANCE : OSHA 1910, ANSI Z359.1-1992

OTHER : No tools required for installation